

# SMI81 SERIES

## 60° & 55° INCLUDED ANGLES

Nom. Diam. in MM	No. Teeth in Part	Pitch Dia.	Bore	No. of Teeth	Whole Depth	Specify Ground or Unground
<b>60° INCLUDED ANGLES</b>						
44 x 40	38	1.2	1/2	26	.0809	SME81-44 - 40 H
50 x 45	39	1.4	1/2	27	.0961	SME81-50 - 45 H
55 x 50	40	1.45	1/2	28	.0970	SME81-55 - 50 H
60 x 55	42	1.7	1/2	30	.0994	SME81-60 - 55 H
<b>55° INCLUDED ANGLES</b>						
65 x 60	41	1.5	1/2	26	.0996	SME81-41 H
70 x 65	45					
75 x 70	48	1.5	1/2	26	.0984	SME81-55 H
80 x 75	51					
85 x 80	55					
90 x 85	58					
95 x 90	61	3	1-1/4	50	.0984	SME81-68 3
100 x 95	65					
105x100	68					
110x105	71					
115x110	75					
120x115	78					
125x120	81					

### DIN 5481 Serration Straight-Sided Internal

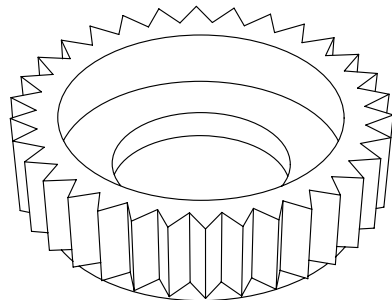

# SME81 SERIES

## 60° & 55° INCLUDED ANGLES

Nom. Diam. in MM	No. Teeth in Part	Pitch Dia.	Bore	No. of Teeth	Whole Depth	Series
<b>60° INCLUDED ANGLES</b>						
8 x 7	28	1.5	1/2	144	.0179	SME81-8-7 H
10 x 8	28	1.5	1/2	120	.0305	SME81-10-8 H
12 x 10	30	1.5	1/2	104	.0297	SME81-12-10 H
14 x 12	31	3	1-1/4	180	.0364	SME81-14-12 H
17 x 15	32	3	1-1/4	152	.0394	SME81-17-15 H
20 x 17	33	3	1-1/4	136	.0459	SME81-20-17 S
24 x 21	34	3	1-1/4	116	.0559	SME81-24-21 S
30 x 26	35	3	1-1/4	96	.0650	SME81-30-26 S
34 x 30	36	3	1-1/4	84	.0652	SME81-34-30 S
40 x 36	37	3	1-1/4	74	.0717	SME81-40-36 S
44 x 40	38	3	1-1/4	68	.0780	SME81-44-40 S
50 x 45	39	3	1-1/4	62	.0927	SME81-50-45 S
55 x 50	40	3	1-1/4	58	.0953	SME81-55-50 S
60 x 55	42	3	1-1/4	55	.0965	SME81-60-55 S
<b>55° INCLUDED ANGLES</b>						
65 x 60	41	3	1-1/4	51	.099	SME81-41-3
70 x 65	45					
75 x 70	48					
80 x 75	51					
85 x 80	55					
90 x 85	58					
95 x 90	61					
100 x 95	65					
105x100	68					
110x105	71					
115x110	75					
120x115	78					
125x120	81					

The above shaper will cut the complete upper range: 65mm – 125mm

## DIN 5481 Serration Straight-Sided External

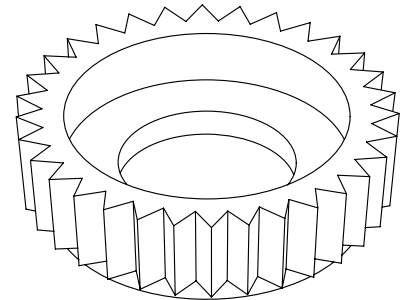

*Formerly SME60 & SME55 Series.*