

SM45 SERIES

45° PA

Module	Pitch Dia.	Bore	No. Teeth	Whole Depth	Series
0.25	1.5	1/2	152	.0098	SM45-025-H
0.4	1.5	1/2	96	.0157	SM45-040-H
0.5	1.5	1/2	75	.0197	SM45-050-H
0.6	1.5	1/2	62	.0246	SM45-060-H
0.7	1.5	1/2	54	.0276	SM45-070-H
0.75	1.5	1/2	48	.0295	SM45-075-H
0.75	3	1-1/4	102	.0295	SM45-075-3
0.8	1.5	1/2	46	.0315	SM45-080-H
1	1.5	1/2	38	.0394	SM45-100-H
1	2.5	1-1/4	64	.0394	SM45-100-3
1.25	1.5	1/2	30	.0492	SM45-125-H
1.25	2.5	1-1/4	51	.0492	SM45-125-3
1.5	1.5	1/2	25	.0591	SM45-150-H
1.5	3	1-1/4	51	.0591	SM45-150-3
1.75	1.5	1/2	22	.0689	SM45-175-H
1.75	3	1-1/4	44	.0689	SM45-175-3
2	1.5	1/2	19	.0787	SM45-200-H
2	3	1-1/4	38	.0787	SM45-200-3
2.25	3	1-1/4	34	.0886	SM45-225-3
2.5	1.5	1/2	15	.0984	SM45-250-H
2.5	3	1-1/4	30	.0984	SM45-250-3

MODULE

Full Fillet

Involute Spline, Disc Type Finishing, Non-Topping

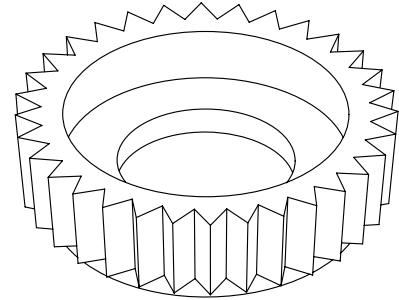

ANSI B92.2M-1980
1.00/DP = WD

