

SM37 SERIES

37-1/2° PA

Module	Pitch Dia.	Bore	No. Teeth	Whole Depth	Series
0.25	1.5	1/2	10	.0113	SM37-025-H
0.5	1.5	1/2	75	.0226	SM37-050-H
0.5	2.5	1-1/4	127	.0226	SM37-050-2
0.75	1.5	1/2	48	.0340	SM37-075-H
0.75	3	1-1/4	100	.0340	SM37-075-3
1	1.5	1/2	38	.0453	SM37-100-H
1	3	1-1/4	76	.0453	SM37-100-3
1.25	1.5	1/2	30	.0566	SM37-125-H
1.5	1.5	1/2	25	.0679	SM37-150-H
1.5	3	1-1/4	50	.0679	SM37-150-3
1.75	1.5	1/2	22	.0792	SM37-175-H
1.75	3	1-1/4	44	.0792	SM37-175-3
2	1.5	1/2	19	.0906	SM37-200-H
2	3	1-1/4	38	.0906	SM37-200-3
2.5	1.5	1/2	15	.1132	SM37-250-H
2.5	3	1-1/4	30	.1132	SM37-250-3
3	1.5	1/2	13	.1358	SM37-300-H
3	3	1-1/4	25	.1358	SM37-300-3
4	3	1-1/4	19	.1811	SM37-400-3
4	4	1-1/4	25	.1811	SM37-400-4
5	3	1-1/4	15	.2264	SM37-500-3
5	4	1-1/4	20	.2264	SM37-500-4
6	3	1-1/4	13	.2717	SM37-600-3
6	4	1-1/4	17	.2717	SM37-600-4
8	4	1-1/4	13	.3622	SM37-800-4
10	4	1-1/4	10	.4528	SM37-1000-4

MODULE

Full Fillet

Involute Spline, Disc Type

Finishing, Non-Topping

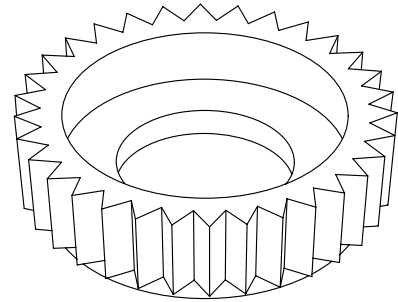

ANSI B92.2M-1980
1.15/DP = WD

