

MODULE
Finishing, Disc Type
Non-Topping

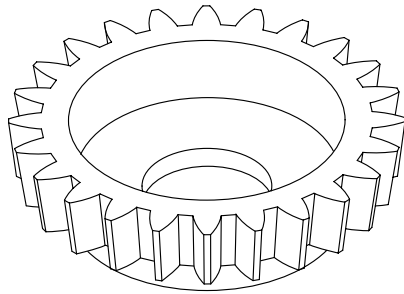

$2.25/DP = WD$

SM20 SERIES
20° PA

Module	Pitch Dia.	Bore	No. Teeth	Whole Depth	Series
0.25	1.5	1/2	152	.0237	SM20-025-H
0.3	1.5	1/2	128	.0279	SM20-030-H
0.35	1.5	1/2	108	.0323	SM20-035-H
0.4	1.5	1/2	96	.0366	SM20-040-H
0.4	2.5	1-1/4	160	.0366	SM20-040-2
0.4	3	1-1/4	180	.0366	SM20-040-3
0.45	1.5	1/2	84	.0410	SM20-045-H
0.5	1.5	1/2	80	.0453	SM20-050-H
0.5	3	1-1/4	150	.0453	SM20-050-3
0.5	4	1-1/4	200	.0453	SM20-050-4
0.55	1.5	1/2	70	.0496	SM20-055-H
0.6	1.5	1/2	62	.0540	SM20-060-H
0.6	3	1-1/4	128	.0540	SM20-060-3
0.65	1.5	1/2	60	.0583	SM20-065-H
0.7	1.5	1/2	54	.0626	SM20-070-H
0.7	3	1-1/4	108	.0626	SM20-070-3
0.75	1.5	1/2	50	.0670	SM20-075-H
0.75	3	1-1/4	100	.0670	SM20-075-3
0.75	4	1-1/4	128	.0670	SM20-075-4
0.8	1.5	1/2	46	.0713	SM20-080-H
0.8	3	1-1/4	96	.0713	SM20-080-3
0.85	1.5	1/2	45	.0756	SM20-085-H
0.9	1.5	1/2	42	.080	SM20-090-H
0.9	3	1-1/4	84	.080	SM20-090-3
0.95	1.5	1/2	40	.0843	SM20-095-H
1	1.5	1/2	38	.0886	SM20-100-H
1	3	1-1/4	76	.0886	SM20-100-3
1	4	1-1/4	100	.0886	SM20-100-4
1	5	1-3/4	128	.0886	SM20-100-5
1.125	3	1-1/4	76	.0997	SM20-112-3
1.25	1.5	1/2	30	.1107	SM20-125-H
1.25	3	1-1/4	60	.1107	SM20-125-3
1.25	4	1-1/4	80	.1107	SM20-125-4
1.25	5	1-3/4	100	.1107	SM20-125-5
1.375	3	1-1/4	54	.1218	SM20-137-3
1.5	1.5	1/2	26	.1329	SM20-150-H
1.5	3	1-1/4	51	.1329	SM20-150-3
1.5	4	1-1/4	68	.1329	SM20-150-4
1.5	5	1-3/4	84	.1329	SM20-150-5
1.75	1.5	1/2	22	.155	SM20-175-H

(continued on next column)

SM20 SERIES
20° PA (continued)

Module	Pitch Dia.	Bore	No. Teeth	Whole Depth	Series
1.75	3	1-1/4	44	.155	SM20-175-3
1.75	4	1-1/4	58	.155	SM20-175-4
1.75	5	1-3/4	72	.155	SM20-175-5
2	1.5	1/2	19	.1772	SM20-200-H
2	3	1-1/4	38	.1772	SM20-200-3
2	4	1-1/4	50	.1772	SM20-200-4
2	5	1-3/4	64	.1772	SM20-200-5
2.25	1.5	1/2	17	.1993	SM20-225-H
2.25	3	1-1/4	34	.1993	SM20-225-3
2.25	4	1-1/4	45	.1993	SM20-225-4
2.5	1.5	1/2	15	.2214	SM20-250-H
2.5	3	1-1/4	30	.2214	SM20-250-3
2.5	4	1-1/4	40	.2214	SM20-250-4
2.5	5	1-3/4	50	.2214	SM20-250-5
2.75	1.5	1/2	14	.2436	SM20-275-H
2.75	3	1-1/4	28	.2436	SM20-275-3
2.75	4	1-1/4	36	.2436	SM20-275-4
2.75	5	1-3/4	46	.2436	SM20-275-5
3	1.5	1/2	14	.2657	SM20-300-H
3	3	1-1/4	25	.2657	SM20-300-3
3	4	1-1/4	34	.2657	SM20-300-4
3	5	1-3/4	42	.2657	SM20-300-5
3.25	1.5	1/2	12	.2879	SM20-325-H
3.25	3	1-1/4	24	.2879	SM20-325-3
3.25	4	1-1/4	32	.2879	SM20-325-4
3.25	5	1-3/4	40	.2879	SM20-325-5
3.5	2	1/2	13	.3100	SM20-350-S
3.5	3	1-1/4	22	.3100	SM20-350-3
3.5	4	1-1/4	29	.3100	SM20-350-4
3.5	5	1-3/4	36	.3100	SM20-350-5
3.75	2	3/4	14	.3321	SM20-375-S
3.75	4	1-1/4	27	.3321	SM20-375-4
4	1.5	1/2	10	.3543	SM20-400-H
4	2.5	3/4	14	.3543	SM20-400-S
4	3	1-1/4	19	.3543	SM20-400-3
4	4	1-1/4	25	.3543	SM20-400-4
4	5	1-3/4	32	.3543	SM20-400-5
4	6	1-3/4	38	.3543	SM20-400-6
4.25	3	1-1/4	18	.3765	SM20-425-3
4.25	4	1-1/4	24	.3765	SM20-425-4
4.5	2	3/4	11	.3986	SM20-450-S
4.5	3	1-1/4	18	.3986	SM20-450-3
4.5	4	1-1/4	22	.3986	SM20-450-4
4.5	5	1-3/4	28	.3986	SM20-450-5
4.75	3	1-1/4	16	.4208	SM20-475-3
4.75	4	1-1/4	21	.4208	SM20-475-4
5	2	3/4	10	.4429	SM20-500-S
5	3	1-1/4	15	.4429	SM20-500-3
5	4	1-1/4	20	.4429	SM20-500-4
5	5	1-3/4	25	.4429	SM20-500-5
5	6	1-3/4	30	.4429	SM20-500-6
5.25	3	1-1/4	15	.465	SM20-525-3
5.25	4	1-1/4	20	.465	SM20-525-4
5.5	2.2	3/4	10	.4872	SM20-550-S
5.5	3	1-1/4	14	.4872	SM20-550-3
5.5	4	1-1/4	18	.4872	SM20-550-4

(continued on next page)

SM20 SERIES 20° PA (continued)

Module	Pitch Dia.	Bore	No. Teeth	Whole Depth	Series
5.5	5	1-3/4	23	.4872	SM20-550-5
5.75	3	1-1/4	13	.5094	SM20-575-3
5.75	4	1-1/4	17	.5094	SM20-575-4
6	2.4	3/4	10	.5315	SM20-600-S
6	4	1-1/4	17	.5315	SM20-600-4
6	5	1-3/4	22	.5315	SM20-600-5
6	6	1-3/4	25	.5315	SM20-600-6
6.5	2.3	3/4	9	.5758	SM20-650-S
6.5	4	1-1/4	16	.5758	SM20-650-4
6.5	5	1-3/4	20	.5758	SM20-650-5
7	2.75	3/4	10	.6201	SM20-700-S
7	4	1-1/4	15	.6201	SM20-700-4
7	5	1-3/4	18	.6201	SM20-700-5
7	6	1-3/4	22	.6201	SM20-700-6
8	2.6	3/4	8	.7087	SM20-800-S
8	4	1-1/4	13	.7087	SM20-800-4
8	5	1-3/4	16	.7087	SM20-800-5
8	6	1-3/4	19	.7087	SM20-800-6
9	2.6	3/4	7	.7972	SM20-900-S
9	4	1-1/4	12	.7972	SM20-900-4
9	5	1-3/4	14	.7972	SM20-900-5
10	4	1-1/4	10	.8858	SM20-1000-4
10	5	1-3/4	13	.8858	SM20-1000-5
10	6	1-3/4	15	.8858	SM20-1000-6
11	4	1-1/4	9	.9744	SM20-1100-4
11	5	1-3/4	12	.9744	SM20-1100-5
12	5	1-3/4	11	1.0630	SM20-1200-5
12	6	1-3/4	13	1.0630	SM20-1200-6
14	6.6	1-3/4	12	1.2402	SM20-1400-6

MODULE Finishing, Disc Type Non-Topping

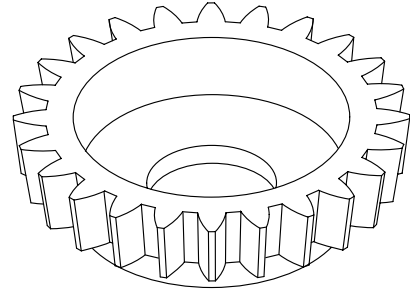

$$2.25/DP = WD$$

SM84 SERIES 4" BORE, 20° PA

Module	Diam.	Whole Teeth	Depth	Series
3	8	68	.2657	SM84-300-3
4	8	51	.3543	SM84-400-4
5	8	40	.4429	SM84-500-5
6	8	34	.5315	SM84-600-6
7	8	29	.6201	SM84-700-7
8	8	25	.7087	SM84-800-8
9	8	23	.7972	SM84-900-9
10	8	20	.8858	SM84-010-10
12	8	17	1.0630	SM84-012-12
14	8.2	15	1.2402	SM84-014-14
16	8.2	13	1.4173	SM84-016-16
18	8.5	12	1.5945	SM84-018-18
20	8.7	11	1.7717	SM84-020-20

MODULE Disc Type, Finishing, Non-Topping, Unaligned Keyway

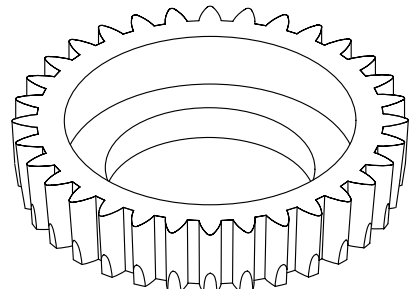

$$2.25/DP = WD$$

SMD20 SERIES 20° PA

MODULE Deep "C" Bore, Finishing Non-Topping

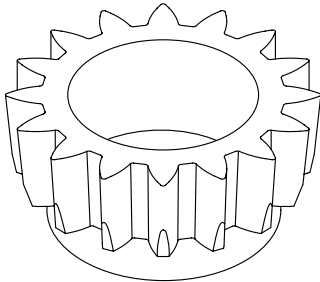

$$2.25/DP = WD$$

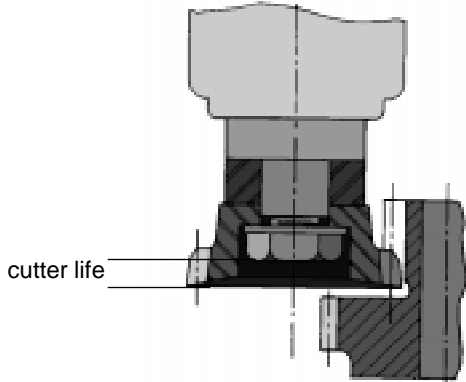

The deep counterbore cutter, sometimes called an extended boss type, is an advantageous option when the clamping nut cannot protrude beyond the cutting face at any time through out the life of the cutter.

Module	Pitch Dia.	Bore	No. Teeth	Whole Depth	Series
0.5	1.5	1/2	80	.0453	SMD20-050-H
0.5	3	1-1/4	150	.0453	SMD20-050-3
0.75	1.5	1/2	50	.0670	SMD20-075-H
0.75	3	1-1/4	100	.0670	SMD20-075-3
1	1.5	1/2	38	.0886	SMD20-100-H
1	3	1-1/4	76	.0886	SMD20-100-3
1	4	1-1/4	100	.0886	SMD20-100-4
1.25	1.5	1/2	30	.1107	SMD20-125-H
1.25	3	1-1/4	60	.1107	SMD20-125-3
1.25	4	1-1/4	80	.1107	SMD20-125-4
1.5	1.5	1/2	26	.1329	SMD20-150-H
1.5	3	1-1/4	51	.1329	SMD20-150-3
1.5	4	1-1/4	68	.1329	SMD20-150-4
1.75	1.5	1/2	22	.155	SMD20-175-H
1.75	3	1-1/4	44	.155	SMD20-175-3
1.75	4	1-1/4	58	.155	SMD20-175-4
2	1.5	1/2	19	.1772	SMD20-200-H
2	3	1-1/4	38	.1772	SMD20-200-3
2	4	1-1/4	50	.1772	SMD20-200-4
2.25	1.5	1/2	17	.1993	SMD20-225-H
2.25	3	1-1/4	34	.1993	SMD20-225-3
2.5	1.5	1/2	15	.2214	SMD20-250-H
2.5	3	1-1/4	30	.2214	SMD20-250-3
2.5	4	1-1/4	40	.2214	SMD20-250-4
2.75	1.5	1/2	14	.2436	SMD20-275-H
2.75	3	1-1/4	28	.2436	SMD20-275-3
3	1.5	1/2	14	.2657	SMD20-300-H
3	3	1-1/4	25	.2657	SMD20-300-3
3	4	1-1/4	34	.2657	SMD20-300-4
3.25	1.5	1/2	12	.2879	SMD20-325-H
3.25	3	1-1/4	24	.2879	SMD20-325-3
3.5	2	3/4	13	.3100	SMD20-350-S
3.5	3	1-1/4	22	.3100	SMD20-350-3
3.5	4	1-1/4	29	.3100	SMD20-350-4
3.75	3	1-1/4	20	.3321	SMD20-375-3
4	2	3/4	12	.3543	SMD20-400-S
4	3	1-1/4	19	.3543	SMD20-400-3
4	4	1-1/4	25	.3543	SMD20-400-4
4.5	2	3/4	11	.3986	SMD20-450-S
4.5	3	1-1/4	18	.3986	SMD20-450-3
4.5	4	1-1/4	22	.3986	SMD20-450-4
5	2	3/4	10	.4429	SMD20-500-S
5	3	1-1/4	15	.4429	SMD20-500-3
5	4	1-1/4	20	.4429	SMD20-500-4
5	5	1-3/4	25	.4429	SMD20-500-5
5.5	4	1-1/4	18	.4872	SMD20-550-4
6	2.4	3/4	10	.5315	SMD20-600-S
6	4	1-1/4	17	.5315	SMD20-600-4
6	5	1-3/4	22	.5315	SMD20-600-5
6.5	4	1-1/4	16	.5758	SMD20-650-4
7	4	1-1/4	15	.6201	SMD20-700-4
7	5	1-3/4	18	.6201	SMD20-700-5
8	2.6	3/4	8	.7087	SMD20-800-S
8	4	1-1/4	13	.7087	SMD20-800-4
8	5	1-3/4	16	.7087	SMD20-800-5
9	4	1-1/4	12	.7972	SMD20-900-4
10	5	1-3/4	13	.8858	SMD20-1000-5