

# SFF30 & SFF30B SERIES

## DP, 30° PA (continued)

### Full Fillet, Involute Spline Finishing, Non-Cham. Disc & Button Type

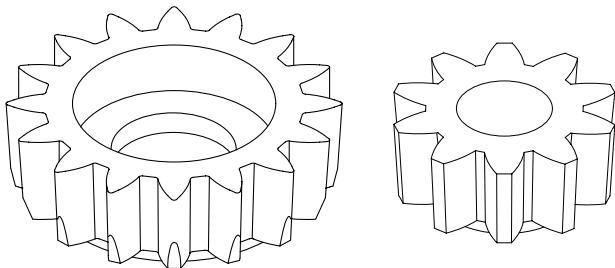

ANSI B92.1-1970/6

For chamfering full fillet inquire on SCF30 series.

### SFF30 & SFF30B SERIES

#### DP, 30° PA

Diam. Pitch	Pitch Dia.	Bore	No. Teeth	Whole Depth	Series
2.5/5	5	1-3/4	13	.560	SFF30-250-5
3/6	3	3/4	9	.4667	SFF30B-3-9S
3/6	3	1-1/4	9	.4667	SFF30-300-3
3/6	4	1-1/4	12	.4667	SFF30-300-4
3/6	5	1-3/4	15	.4667	SFF30-300-5
3/6	6	1-3/4	18	.4667	SFF30-300-6
4/8	1.5	1/2	6	.350	SFF30B-4-6H
4/8	2	1/2	8	.350	SFF30B-4-8H
4/8	2	3/4	8	.350	SFF30B-4-8S
4/8	2.3	3/4	9	.350	SFF30B-4-9S
4/8	3	1-1/4	12	.350	SFF30-400-3
4/8	4	1-1/4	16	.350	SFF30-400-4
4/8	5	1-3/4	20	.350	SFF30-400-5
4/8	6	1-3/4	24	.350	SFF30-400-6
5/10	1.6	1/2	8	.280	SFF30B-5-8H
5/10	1.8	3/4	9	.280	SFF30B-5-9S
5/10	3	1-1/4	15	.280	SFF30-500-3
5/10	4	1-1/4	20	.280	SFF30-500-4
5/10	5	1-3/4	25	.280	SFF30-500-5
5/10	6	1-3/4	30	.280	SFF30-500-6
6/12	1.5	1/2	9	.2333	SFF30B-6-9H
6/12	2	3/4	12	.2333	SFF30B-6-12S
6/12	3	1-1/4	18	.2333	SFF30-600-3
6/12	4	1-1/4	24	.2333	SFF30-600-4
6/12	5	1-3/4	30	.2333	SFF30-600-5
6/12	6	1-3/4	36	.2333	SFF30-600-6
7/16	3	1-1/4	21	.175	SFF30-700-3
7/16	4	1-1/4	28	.175	SFF30-700-4
8/16	1.5	1/2	12	.175	SFF30B-8-12H
8/16	1.8	3/4	14	.175	SFF30B-8-14S
8/16	2	3/4	16	.175	SFF30B-8-16S
8/16	2.5	3/4	20	.175	SFF30B-8-20S
8/16	3	1-1/4	24	.175	SFF30-800-3
8/16	4	1-1/4	32	.175	SFF30-800-4

Diam. Pitch	Pitch Dia.	Bore	No. Teeth	Whole Depth	Series
8/16	5	1-3/4	40	.175	SFF30-800-5
8/16	6	1-3/4	48	.175	SFF30-800-6
10/20	1.4	1/2	14	.140	SFF30B-10-14H
10/20	1.5	3/4	15	.140	SFF30B-10-15S
10/20	1.8	3/4	18	.140	SFF30B-10-18S
10/20	2	3/4	20	.140	SFF30B-10-20S
10/20	3	1-1/4	30	.140	SFF30-010-3
10/20	4	1-1/4	40	.140	SFF30-010-4
10/20	5	1-3/4	50	.140	SFF30-010-5
10/20	6	1-3/4	60	.140	SFF30-010-6
12/24	1.3	1/2	15	.1167	SFF30B-12-15H
12/24	1.5	3/4	18	.1167	SFF30B-12-18S
12/24	1.8	3/4	21	.1167	SFF30B-12-21S
12/24	2	3/4	24	.1167	SFF30B-12-24S
12/24	3	1-1/4	36	.1167	SFF30-012-3
12/24	4	1-1/4	48	.1167	SFF30-012-4
12/24	5	1-3/4	60	.1167	SFF30-012-5
12/24	6	1-3/4	72	.1167	SFF30-012-6
14/28	3	1-1/4	42	.1071	SFF30-014-3
14/28	4	1-1/4	56	.1071	SFF30-014-4
16/32	1.5	1/2	24	.0938	SFF30B-16-24H
16/32	1.8	3/4	30	.0938	SFF30B-16-30S
16/32	2	3/4	32	.0938	SFF30B-16-32S
16/32	3	1-1/4	48	.0938	SFF30-016-3
16/32	4	1-1/4	64	.0938	SFF30-016-4
16/32	5	1-3/4	80	.0938	SFF30-016-5
16/32	6	1-3/4	96	.0938	SFF30-016-6
20/30	1.5	1/2	30	.087	SFF30B-20-30H
20/30	1.8	3/4	36	.087	SFF30B-20-36S
20/30	3	1-1/4	60	.087	SFF30-020-3
20/30	4	1-1/4	80	.087	SFF30-020-4
20/30	5	1-3/4	100	.087	SFF30-020-5
20/40	1.4	1/2	28	.075	SFF30B-20-28H
20/40	1.5	1/2	30	.075	SFF30B-20-30H
20/40	1.8	3/4	36	.075	SFF30B-20-36S
20/40	2	3/4	40	.075	SFF30B-20-40S
20/40	3	1-1/4	60	.075	SFF30-020-3
20/40	4	1-1/4	80	.075	SFF30-020-4
20/40	5	1-3/4	100	.075	SFF30-020-5
20/40	6	1-3/4	120	.075	SFF30-020-6
24/48	1.3	1/2	32	.0625	SFF30B-24-32H
24/48	1.5	1/2	36	.0625	SFF30B-24-36H
24/48	3	1-1/4	72	.0625	SFF30-024-3
24/48	4	1-1/4	96	.0625	SFF30-024-4
24/48	5	1-3/4	120	.0625	SFF30-024-5
32/64	1.25	1/2	40	.0469	SFF30B-32-40H
32/64	1.5	1/2	48	.0469	SFF30B-32-48H
32/64	3	1-1/4	96	.0469	SFF30-032-3
32/64	4	1-1/4	128	.0469	SFF30-032-4
32/64	5	1-3/4	160	.0469	SFF30-032-5
40/80	1.25	1/2	50	.0375	SFF30B-40-50H
40/80	1.5	1/2	60	.0375	SFF30B-40-60H
40/80	3	1-1/4	120	.0375	SFF30-040-3
40/80	4	1-1/4	160	.0375	SFF30-040-4
40/80	5	1-3/4	200	.0375	SFF30-040-5
48/96	1.25	1/2	60	.0313	SFF30B-48-60H
48/96	1.5	1/2	72	.0313	SFF30B-48-72H
48/96	3	1-1/4	144	.0313	SFF30-048-3
48/96	4	1-1/4	192	.0313	SFF30-048-4
48/96	5	1-3/4	240	.0313	SFF30-048-5

(continued on next page)

# SDF30 & SDF30B SERIES

## DP, 30° PA

Diam. Pitch	Pitch Dia.	Bore	No. Teeth	Whole Depth	Series
2.5/5	5	1-3/4	13	.560	SDF30-250-5
2.5/5	6	1-3/4	15	.560	SDF30-250-6
3/6	3	3/4	9	.4667	SDF30B-3-9S
3/6	4	1-1/4	12	.4667	SDF30-300-4
4/8	2	3/4	8	.350	SDF30B-4-8S
4/8	4	1-1/4	16	.350	SDF30-400-4
4/8	5	1-3/4	20	.350	SDF30-400-5
5/10	4	1-1/4	20	.280	SDF30-500-4
5/10	5	1-3/4	25	.280	SDF30-500-5
6/12	2	3/4	12	.2333	SDF30B-6-12S
6/12	4	1-1/4	24	.2333	SDF30-600-4
6/12	5	1-3/4	30	.2333	SDF30-600-5
8/16	2	3/4	16	.175	SDF30B-8-16S
8/16	3	1-1/4	24	.175	SDF30-800-3
8/16	4	1-1/4	32	.175	SDF30-800-4
8/16	5	1-3/4	40	.175	SDF30-800-5
10/20	1.5	3/4	15	.140	SDF30B-10-15S
10/20	3	1-1/4	30	.140	SDF30-010-3
10/20	4	1-1/4	40	.140	SDF30-010-4
10/20	5	1-3/4	50	.140	SDF30-010-5
12/24	1.5	3/4	18	.1167	SDF30B-12-18S
12/24	3	1-1/4	36	.1167	SDF30-012-3
12/24	4	1-1/4	48	.1167	SDF30-012-4
12/24	5	1-3/4	60	.1167	SDF30-012-5
16/32	2	3/4	32	.0938	SDF30B-16-32S
16/32	3	1-1/4	48	.0938	SDF30-016-3
16/32	4	1-1/4	64	.0938	SDF30-016-4
16/32	5	1-3/4	80	.0938	SDF30-016-5
20/40	1.5	1/2	30	.075	SDF30B-20-30H
20/40	3	1-1/4	60	.075	SDF30-020-3
20/40	4	1-1/4	80	.075	SDF30-020-4
24/48	3	1-1/4	72	.0625	SDF30-024-3
24/48	4	1-1/4	96	.0625	SDF30-024-4
32/64	1.25	1/2	40	.0469	SDF30B-32-40H
32/64	3	1-1/4	96	.0469	SDF30-032-3
32/64	4	1-1/4	128	.0469	SDF30-032-4
40/80	3	1-1/4	120	.0375	SDF30-040-3
48/96	3	1-1/4	144	.0313	SDF30-048-3

## Full Fillet, Deep C' Bore Finishing, Involute Spline Non-Chamfering Disc & Button Type

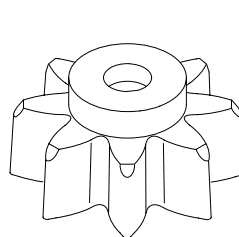

ANSI B92.1-1970

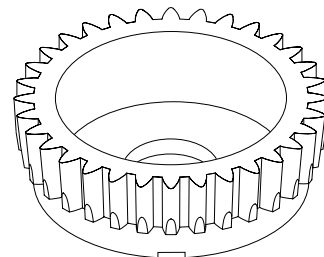

ANSI B92.1-1-1970\*

\*While we show 1970 ANSI standards, ASA B5.15-1950 standards may be available.

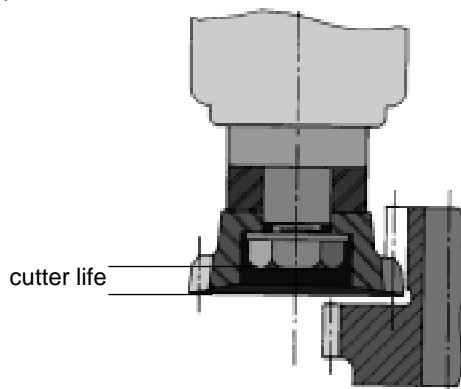

The deep counterbore cutter, sometimes called an extended boss type, is an advantageous option when the clamping nut cannot protrude beyond the cutting face at any time through out the life of the cutter.