

## SDL30 SERIES DP, 30° PA

### Deep C' Bore Flat Root-Side Fit, Disc Type Finishing, Involute Spline Non-Chamfering

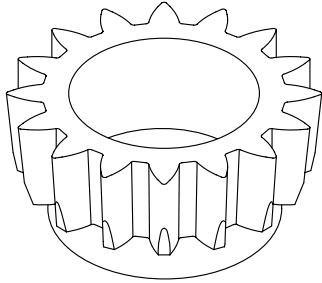

ANSI B92.1-1970

*While we show 1970 ANSI standards, 1950 ASA standards may be available.*

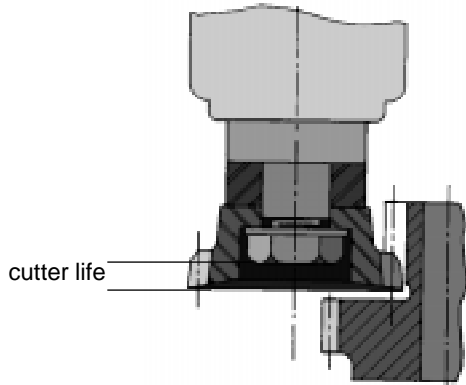

*The deep counterbore cutter, sometimes called an extended boss type, is an advantageous option when the clamping nut cannot protrude beyond the cutting face at any time through out the life of the cutter.*

Diam. Pitch	Pitch Dia.	Bore	No. Teeth	Whole Depth	Series
2.5/5	5	1-3/4	13	.470	SDL30-025-5
2.5/5	6	1-3/4	15	.470	SDL30-025-6
3/6	2.7	3/4	8	.3917	SDL30B-3-8S
3/6	4	1-1/4	12	.3917	SDL30-03-4
3/6	5	1-3/4	15	.3917	SDL30-03-5
4/8	4	1-1/4	16	.294	SDL30-04-4
4/8	5	1-3/4	20	.294	SDL30-04-5
5/10	2	3/4	10	.235	SDL30B-5-10S
5/10	4	1-1/4	20	.235	SDL30-05-4
5/10	5	1-3/4	25	.235	SDL30-05-5
6/12	4	1-1/4	24	.196	SDL30-06-4
6/12	5	1-3/4	30	.196	SDL30-06-5
8/16	3	1-1/4	24	.147	SDL30-08-3
8/16	4	1-1/4	32	.147	SDL30-08-4
8/16	5	1-3/4	40	.147	SDL30-08-5
10/20	1.8	3/4	18	.118	SDL30B-10-18S
10/20	3	1-1/4	30	.118	SDL30-10-3
10/20	4	1-1/4	40	.118	SDL30-10-4
10/20	5	1-3/4	50	.118	SDL30-10-5
12/24	3	1-1/4	36	.098	SDL30-12-3
12/24	4	1-1/4	48	.098	SDL30-12-4
12/24	5	1-3/4	60	.098	SDL30-12-5
16/32	2	3/4	32	.073	SDL30B-16-32S
16/32	3	1-1/4	48	.073	SDL30-16-3
16/32	4	1-1/4	64	.073	SDL30-16-4
16/32	5	1-3/4	80	.073	SDL30-16-5
20/40	3	1-1/4	60	.059	SDL30-20-3
20/40	4	1-1/4	80	.059	SDL30-20-4
24/48	3	1-1/4	72	.049	SDL30-24-3
24/48	4	1-1/4	96	.049	SDL30-24-4
32/64	3	1-1/4	96	.0367	SDL30-32-3
32/64	4	1-1/4	128	.0367	SDL30-32-4
40/80	3	1-1/4	120	.0295	SDL30-40-3
48/96	3	1-1/4	144	.0249	SDL30-48-3