

SDC25 SERIES DP, 25° PA

Deep C' Bore Finishing, Disc Type Non-Topping

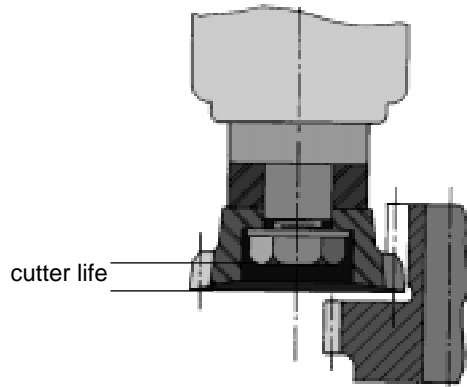

$$2.25/DP=WD$$

$$20DP \text{ and finer } WD = 2.2/DP + .002$$

The deep counterbore cutter, sometimes called an extended boss type, is an advantageous option when the clamping nut cannot protrude beyond the cutting face at any time through out the life of the cutter.

Diam. Pitch	Pitch Dia.	Bore	No. Teeth	Whole Depth	Series
2	5	1-3/4	10	1.125	SDC25-200-5
2-1/2	5	1-3/4	13	.900	SDC25-250-5
3	4	1-1/4	12	.750	SDC25-300-4
3	5	1-3/4	15	.750	SDC25-300-5
3-1/2	4	1-1/4	14	.6429	SDC25-350-4
4	4	1-1/4	16	.5625	SDC25-400-4
4	5	1-3/4	20	.5625	SDC25-400-5
5	4	1-1/4	20	.450	SDC25-500-4
6	3	1-1/4	18	.375	SDC25-600-3
6	4	1-1/4	24	.375	SDC25-600-4
8	3	1-1/4	24	.2813	SDC25-800-3
8	4	1-1/4	32	.2813	SDC25-800-4
10	3	1-1/4	30	.225	SDC25-010-3
10	4	1-1/4	40	.225	SDC25-010-4
12	3	1-1/4	36	.1875	SDC25-012-3
12	4	1-1/4	48	.1875	SDC25-012-4
14	3	1-1/4	42	.1607	SDC25-014-3
14	4	1-1/4	56	.1607	SDC25-014-4
16	3	1-1/4	48	.1406	SDC25-016-3
16	4	1-1/4	64	.1406	SDC25-016-4
20	3	1-1/4	60	.112	SDC25-020-3
24	3	1-1/4	72	.0937	SDC25-024-3
32	3	1-1/4	96	.0708	SDC25-032-3
48	3	1-1/4	144	.0478	SDC25-048-3